



*Australian Railway Kits*  
ABN: 27 416 246 418

Incorporating Main West Models  
Manufacturers, Wholesalers and Retailers of Quality Australian Model Railways  
PO Box 252 Warwick, Queensland, 4370 Australia  
Phone/Fax: 617 4667 1351 Website: [www.arkits.com](http://www.arkits.com) Email: [info@arkits.com](mailto:info@arkits.com)

## **CREATING THE CONTRACT 2 WHX**

### **Al Cutmore**

1. Much has not been written about the NSWGR WHX wagons. They were first introduced into service in July 1968 to Jan 1969 as an order with A.E. Goodwin for 118 wagons numbered 30551 to 30668. The wagons proved successful and a further order for 100 additional wagons to the same specs was placed Tulloch Ltd. These wagons were delivered with numbers 30669 to 30768. But that is about where the similarity finished.
2. The wagons from a half mile look similar but up close the only parts that really stayed the same were the barrels and the discharge mechs.
3. Major differences are the ends of the side sills, location of the brake operating handle, brake rigging, piping, and barrel end support brackets.
4. Included with your notes are drawing of the Contract 1 Model which will assist you in your modelling. Further additions to these drawings and other drawings for Contract 2 will shortly be available on the AR Kits website ([www.arkits.com](http://www.arkits.com)).
5. What we are doing here this weekend is making the mods to the standard AR Kit WHX (Contract 1) to make the WHX (Contract 2) to an acceptable model for your pleasure and maybe frustration.

#### **WHX Floor**

6. There are two methods of assembling the floor. First method is the use of the CH coal hopper floor as well as the in kit WHX floor. This by far the easiest method. Cut the ends off the CH floor at the shown point and sand back square. Put aside. Cut the discharge hoppers from the WHX floor at the point shown and sand back square. Marry up the CH ends and the WHX floor and glue to-gether. Set aside to cure. No reinforcing is required.
7. The second method is to file out the corner gussets of the in kit WHX floor as per Method 2 Diagram 1-1 and 1-3. Glue in pieces of sheet styrene and file/sand to the contours of the side sill as per diagram 1-2. Remove the brake brackets.

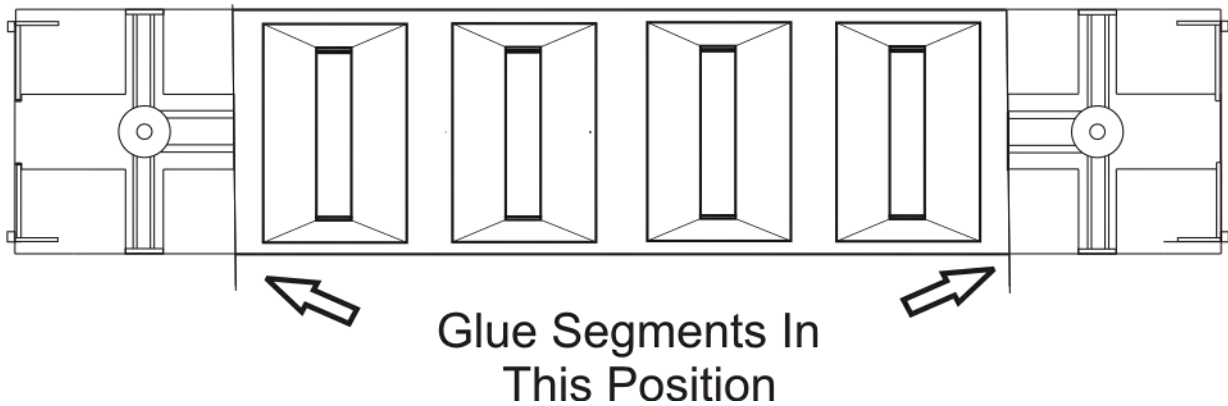
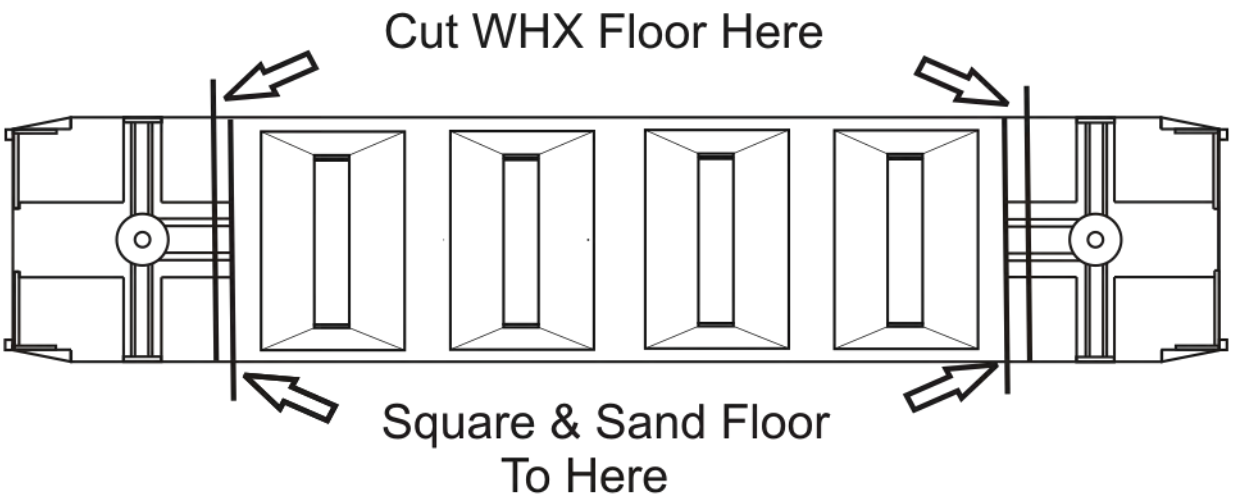
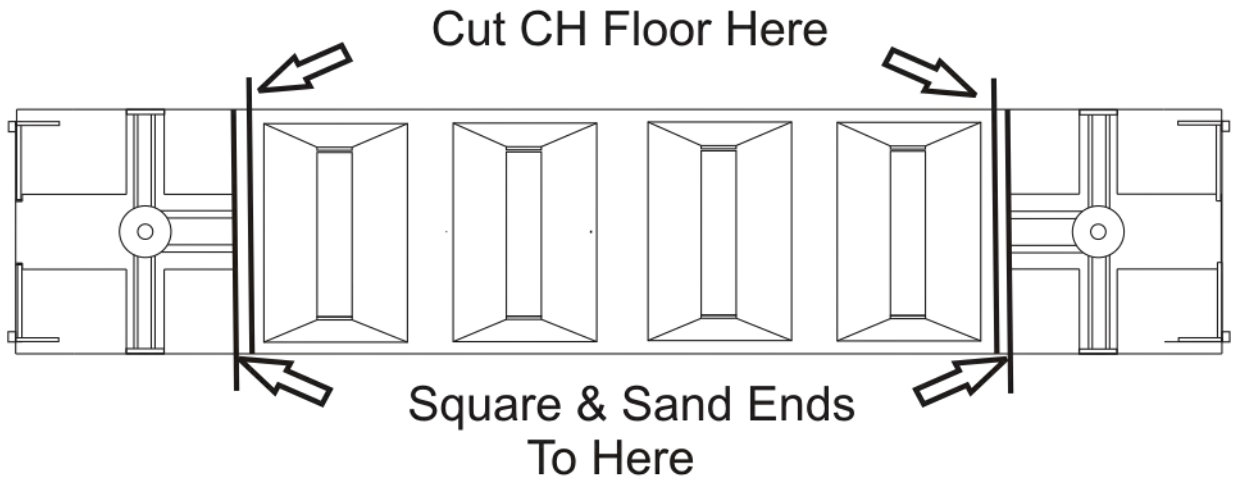
#### **Assembling and Detailing**

8. Using pieces of sprue glue to the floor inline with the outer edge of the discharge chute.
9. Assemble the barrel per the normal instruction.

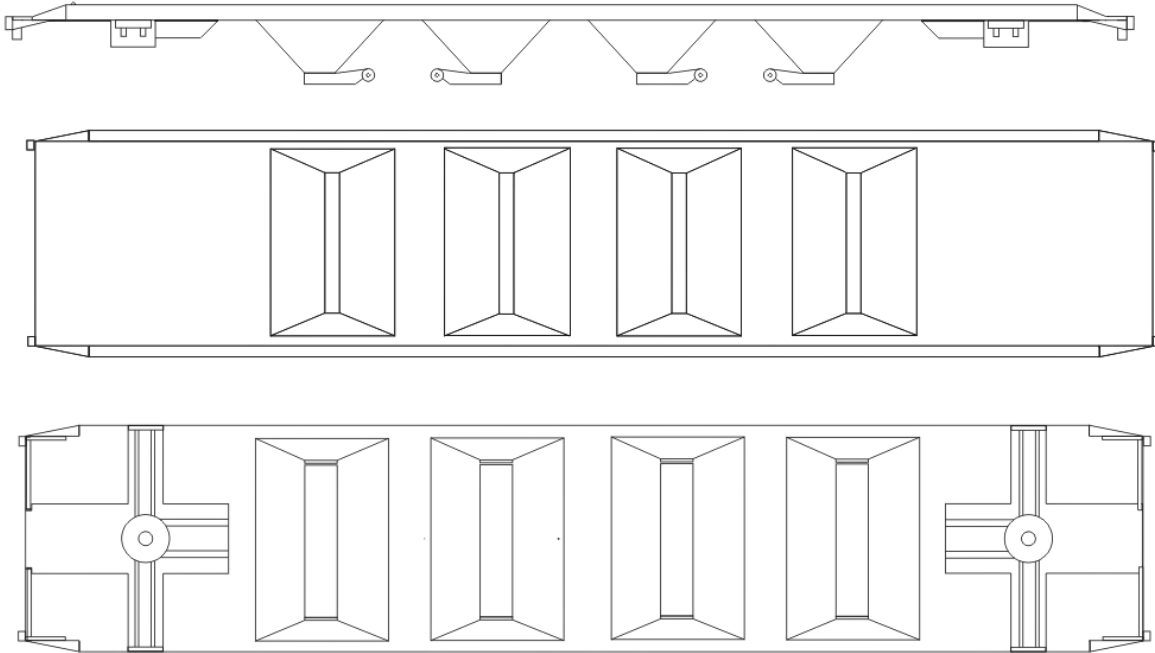
10. Using the plans provided as a guide construct a triple valve mounting frame.. There is no known model of the triple valve use but it can be simulated by using styrene strip and sheet and parts from the AR Kits underbody detailing kit. The major brake reservoir will need to be constructed from styrene tube or rod.
11. and the ends rounded off. Make up mounting brackets from strip styrene. Other aux brake reservoirs can be used from the underbody detailing parts.
12. The end reinforcing supports are made from 1.5mm Evergreen angle. Make a jig of a triangular shape from 1.5mm styrene as a guide to the placement of the supports.
13. Glue four gussets on the side sill as per the diagram. Make two brake brackets from sheet styrene and glue in position. Determine whether you are using the in kit ladder, walkway and brake wheel or the KRM brass kit. Glue in position.
14. Final super detailing is up to the individual modeller including air lines, coupler levers, steps and hand grabs.
15. A good supply of photographs is also essential. A recent segment on ARDP showed a good selection of WHX details photos.

References:       AMRM Issues 89 and 90  
                      Railway Freight Wagons of NSW by John Beckhause  
                      NSWGR Wagon Diagrams

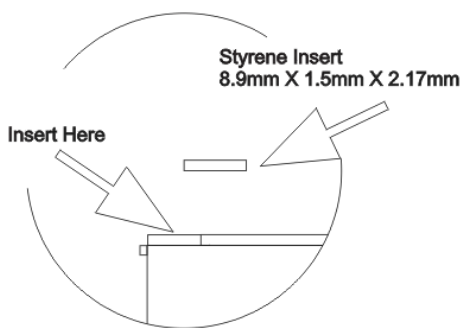
# Method 1 Diagram



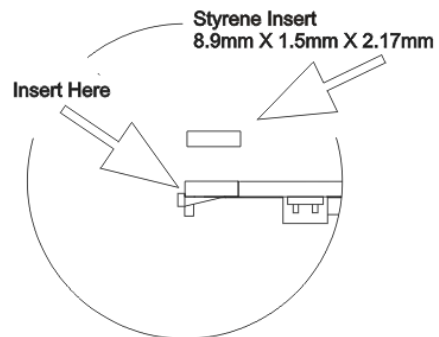
# Method 2 Diagram



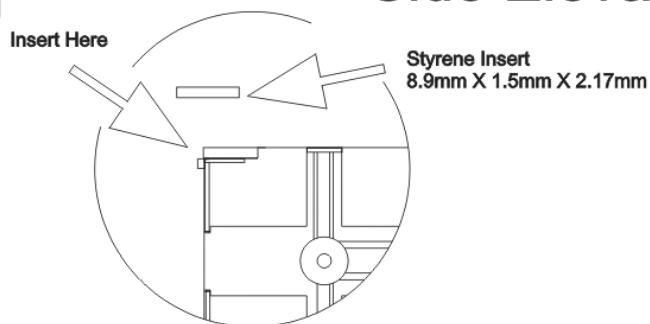
Elevation & Plans of WHX  
Contract 1 Items As Supplied



**Diagram 1-1**  
**Upper Plan**

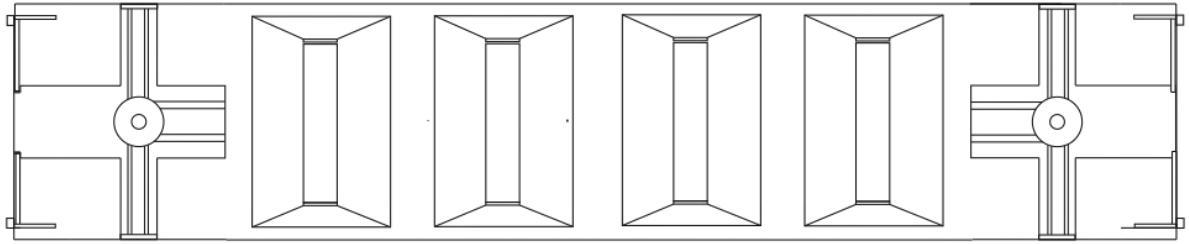


**Diagram 1 - 2**  
**Side Elevation**

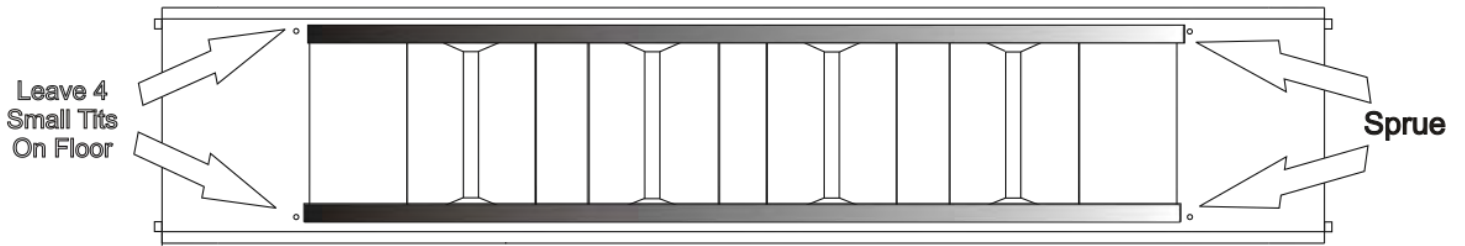


**Diagram 1 - 3**  
**Lower Plan**

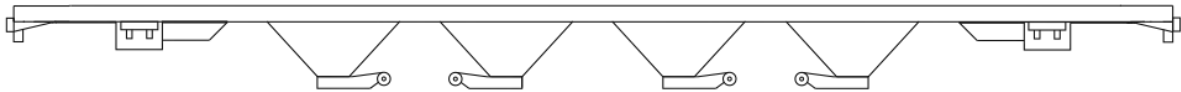
# Finished Floor



Lower Plan

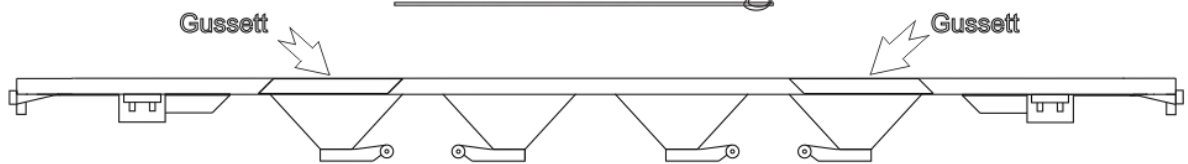


Upper Plan

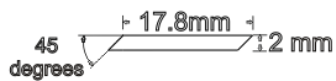


Side Elevation

# Floor Detailing

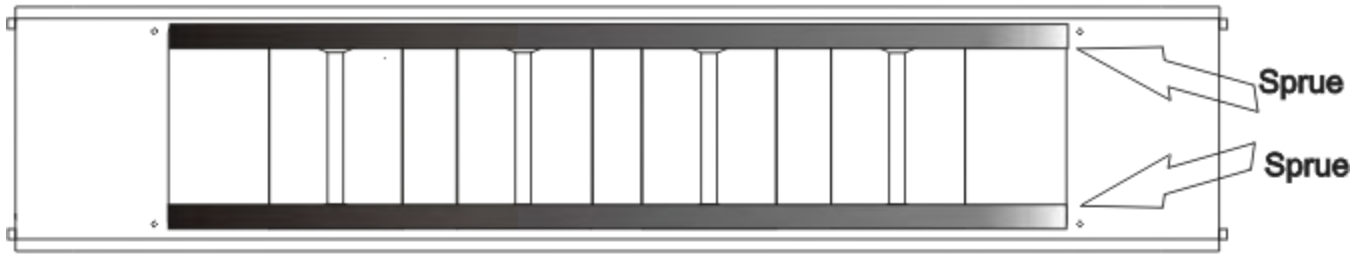


Side Elevation with Gussets Applied

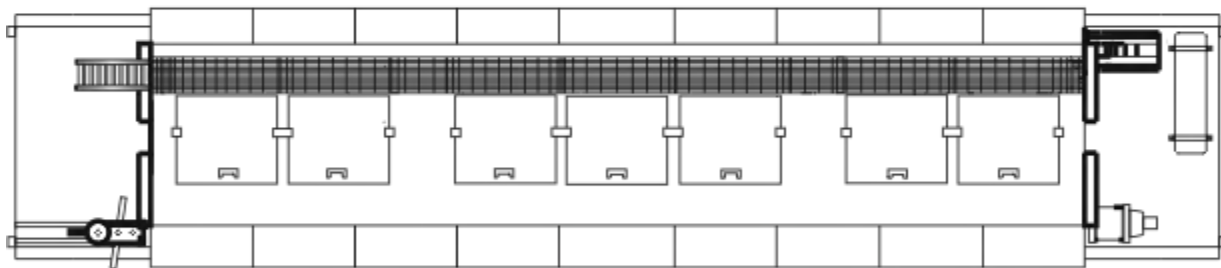


4 X Side Gussets Required 17.8mm X 2mm Cut at 45 degrees

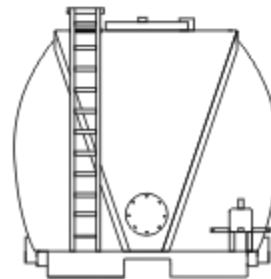
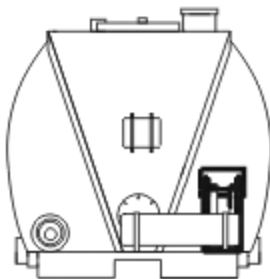
# WHX CONTRACT 2 ASSEMBLY AND DETAILING



**Barrell Scribe Lines 13.1 mm Apart**



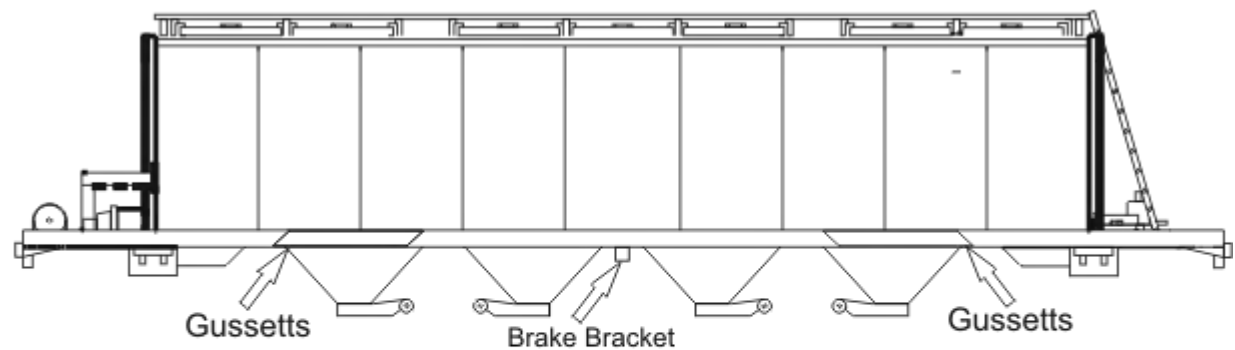
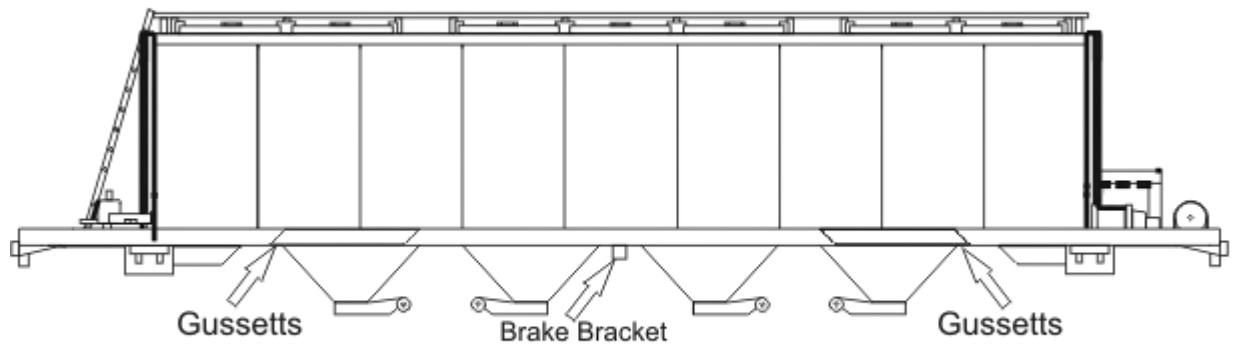
**Barrell Installation**



**End Elevation Detail Location**

# WHX CONTRACT 2 ASSEMBLY AND DETAILING

## Page 2



**Brake Brackets X 2**  
**1.8mm X 1.8mm**



**Gussetts Required for**  
**Chassis Side Rail x 4**  
**17.8mm X 2mm with**  
**ends cut at 45 degrees**